

Gama Hidrófuga [módulos de cocina]

Gama profesional de módulos de cocina hidrófugos compuestos por piezas mecanizadas de FIMAPLAST HID resistente a la humedad.

CARACTERÍSTICAS PRINCIPALES

SOPORTE	FIMAPLAST hidrófugo 16 mm Diseño 2 caras con acabado
CANTO	El frente con PVC 1 mm y en el resto 0,4 mm
TRASERA	FIMAPLAST Diseño / Kraft o Blanco 2 caras 6 mm
EMBALAJE	Retractilado con identificación HIDRÓFUGO



Mecanizado para colgador oculto



Colgadores no incluidos.

Válida aleta 40 / 50 mm



Patas no incluidas

Parte trasera módulos: espacio para enchufes, tuberías y ventilación.

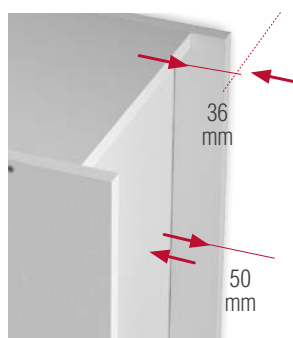

taladros para bisagra: Ø 5 mm

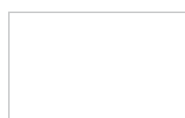

Blanco *Soft III*



Aluminio *Soft III*



Moka Chic *Soft III*



Lissa Oak Poro Profundo

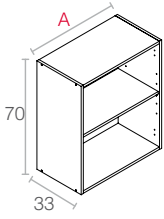

Módulo Superior					
A	30	35	40	45	50
	60	70	80	90	100

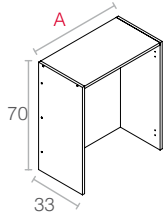

Módulo Superior escurreplatos			
A	60	80	90

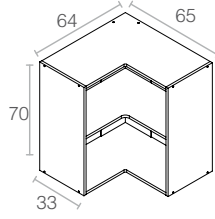

Módulo Superior Esquina "L"

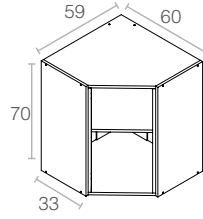

Módulo Superior Rinconero Chafán

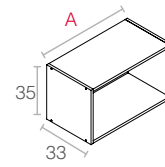

Módulo Superior Horizontal Altura 35		
A	60	90

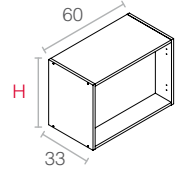

Módulo Superior Sobrecampana		
H	42	62

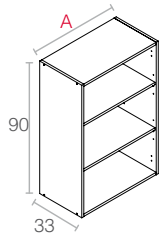

Módulo Superior					
A	30	35	40	45	50
	60	70	80	90	100

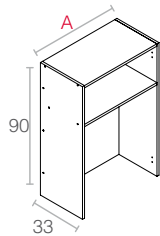

Módulo Superior Escurreplatos			
A	60	80	90

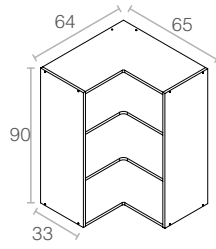

Módulo Superior Esquina "L"

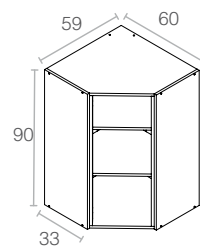

Módulo Superior Rinconero Chafán

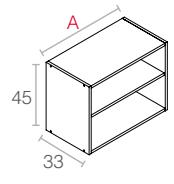

Módulo Superior Horizontal Altura 45			
A	60	90	120

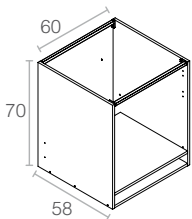

Módulo Inferior						
A	30	35	40	45	50	60
	70	80	90	100	120	

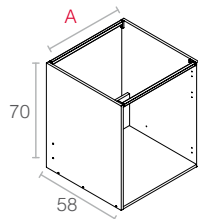

Módulo Inferior Fregadero				
A	45	50	60	80
	90	100	120	

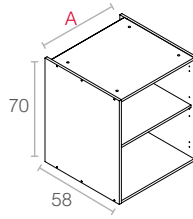

Módulo Inferior						
A	30	35	40	45	50	60
	70	80	90	100	120	

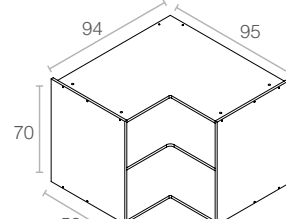

Módulo Inferior Esquina "L"

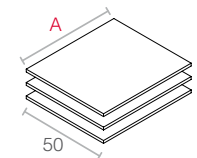

Pack de baldas móviles		
A	36,7 (40)	56,7 (60)

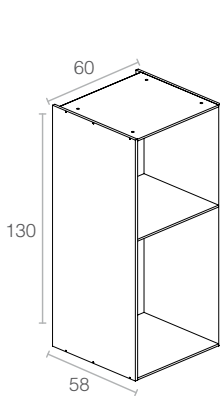

Módulo Semicolumna

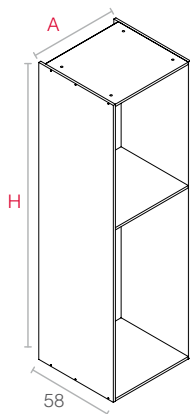

Módulo Columna Dispensero			
HxA	200x40	200x60	
	220x40	220x60	

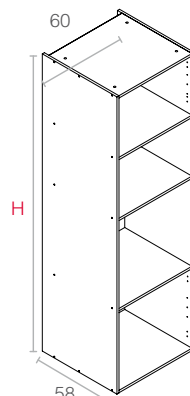

Módulo Columna Horno-Micro	
H	200x60
	220x60

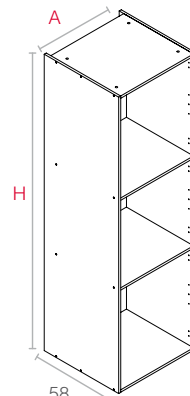

Módulo Columna Horno Dispensero			
HxA	200x40	200x60	
	220x40	220x60	

Gama Hidrófuga [módulos de cocina]

- La evolución del módulo de cocina.
- Nuevo diseño de interior más moderno.
- Mecanizado interior más cuidado.
- Mayor capacidad de almacenaje.

CARACTERÍSTICAS PRINCIPALES

SOPORTE	FIMAPLAST hidrófugo 16 mm Diseño 2 caras con acabado
CANTO	El frente con PVC 1 mm y en el resto 0,4 mm
TRASERA	FIMAPLAST 6mm Moka Chic y Sahara
EMBALAJE	Retractilado con identificación HIDRÓFUGO

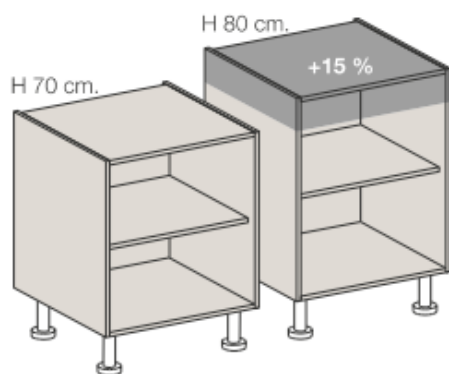

15% más de capacidad

taladros
para bisagra:
Ø 5 mm



Taladros interiores 3mm

Mecanizado para colgado
oculto



Colgadores no incluidos

Válida aleta 40 / 50mm



Patas no incluidas

Gama Hidrófuga [módulos de cocina]

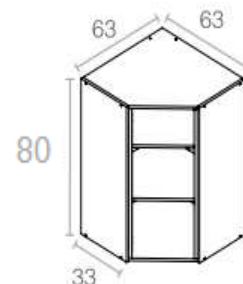
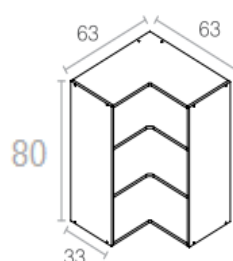
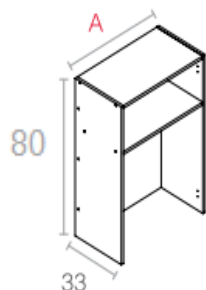
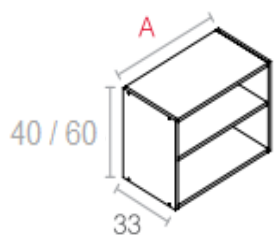
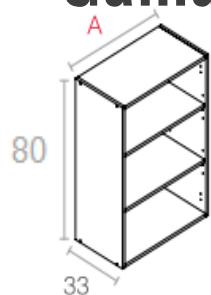

Módulo Superior				
A	35	40	45	50
	60	70	80	100

Módulo Superior Horizontal	
A	60 90

Módulo Superior Escurridor		
A	60	80 90

Módulo Superior Esquina " L "

Módulo Superior Esquina Chaflán

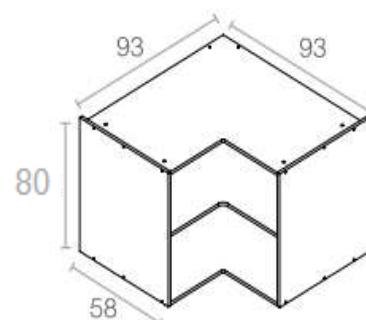
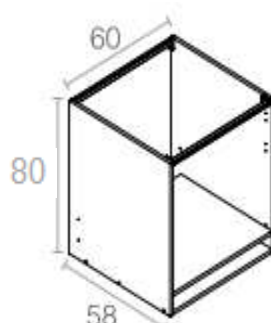
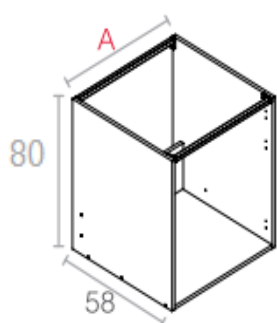
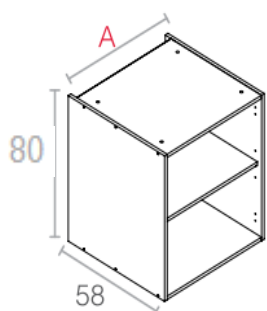

Módulo Inferior				
A	35	40	45	50
	60	70	80	100

Módulo inferior Fregadero				
A	45	50	60	70
	80	90	100	120

Módulo Inferior Horno

Módulo Inferior Esquina " L "

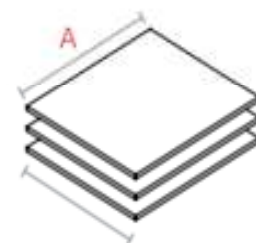
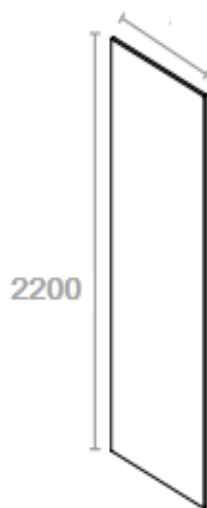
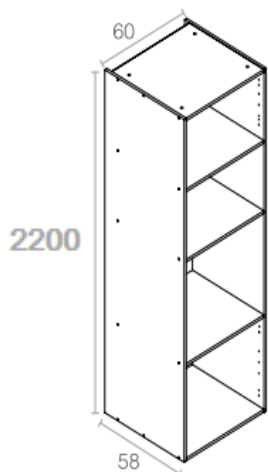
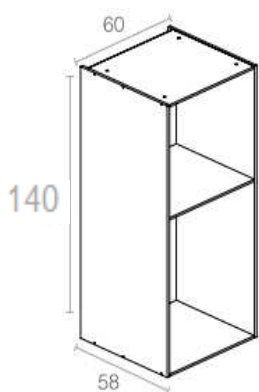

Kit Interior columna 3 estantes móviles Tapa + Base 1 estante fijo.

A	300	350	400	450	500	600
---	-----	-----	-----	-----	-----	-----

* NO contienen herrajes se venden por separado

Módulo Inferior Semicolumna

Módulo Inferior Columna H+M

Kit costados + trasera columna Dispensero

Kit costados + trasera columna Regulable